

Natural Ventilation Controller

SN 5012

USER'S MANUAL

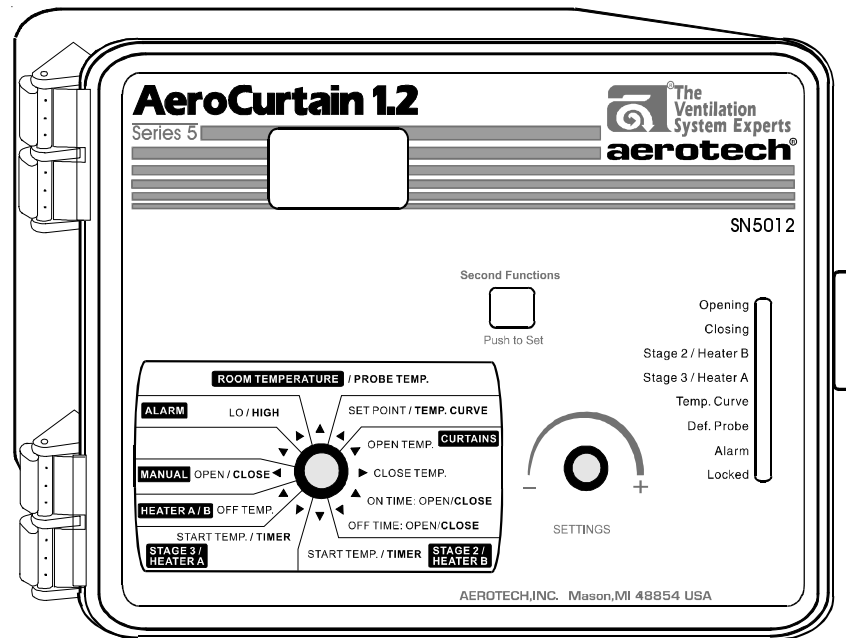

TABLE OF CONTENTS

	Page
PRECAUTIONS	3
FEATURES	4
LOCATION OF THE CONTROLS	6
Controller Status Leds	7
Internal Switches	7
INSTALLATION	8
Mounting Instructions	8
Connections	8
Temperature Probes	9
CONFIGURATIONS	11
CHANGING THE PARAMETER SETTINGS	18
The Meaning of a Flashing Display	18
Locking the Parameters Settings	18
TEMPERATURE SETTINGS	19
Temperature Units	19
Viewing Temperatures	19
Temperature Set Point	22
Temperature Curve	23
NATURAL VENTILATION	27
Principle of Operation	27
Settings	28
Curtain Operating Time Compensation	30
VENTILATION AND MIST SETTINGS	32
HEATER SETTINGS	34
ALARM SETTINGS	39
TEST MODE	40
TROUBLESHOOTING GUIDE	40
TECHNICAL SPECIFICATIONS	43
FACTORY SETTINGS	44

PRECAUTIONS

We strongly recommend installing supplementary natural ventilation, a failure alarm system as well as a back-up thermostat on at least one cooling stage (refer to the wiring diagram enclosed with this user's manual to connect the thermostat).

Although fuses at the input and outputs of the controller protect its circuits in case of an overload or overvoltage, we recommend installing an additional protection device on the supply circuit as well as an external relay on all ON-OFF stages to prolong the life of the controller.

The room temperature where the controller is located **MUST ALWAYS REMAIN BETWEEN 32°F AND 104°F (0°C TO 40°C)**.

To avoid exposing the controller to harmful gases or excessive humidity, it is preferable to install it in a corridor.

DO NOT SPRAY WATER ON THE CONTROLLER

FOR CUSTOMER USE

Enter below the serial number located on the side of the controller and retain this information for future reference.

Model number: SN 5012

Serial number:

Date installed:

FEATURES

The SN 5012 is an electronic device used for environmental control in livestock buildings. It allows the user to maintain a specified target temperature by controlling the operation of ventilation and heating equipment. Two stages combining constant-speed fans, heating units or mist sprinklers, as well as curtains for natural ventilation, can be connected to the controller.

The main features of the SN 5012 are as follows:

THREE-DIGIT DISPLAY

A three-digit display provides a high level of accuracy, allowing the user to specify a temperature to within one tenth of a degree (in Fahrenheit or Celsius units).

PILOT LIGHTS

Pilot lights indicating the state of outputs allow the user to monitor the operation of the system without having to enter the building.

MINIMUM VENTILATION CYCLE

When ventilation is not required for cooling, stage 2 and 3 fans can be operated either continuously or intermittently to reduce the level of humidity and supply oxygen to the room.

TEMPERATURE CURVE

The controller can be set to automatically change the temperature set point over a given period of time in accordance with the user's requirements by specifying a temperature curve with up to six different points.

FOUR INDEPENDENT TEMPERATURE PROBE INPUTS

Up to four temperature probes can be connected to the controller in order to obtain a more accurate reading of the average room temperature and a faster reaction time.

HIGH/LOW TEMPERATURE ALARM OUTPUT

ZONED OR STAGED HEATERS

SN 5012

ROOM TEMPERATURE COMPENSATION ON CURTAINS

The controller compensates the curtain timer settings proportionally to room temperature. The lower the temperature, the faster the curtains close. The higher the temperature, the faster the curtains open.

OVERLOAD AND OVERVOLTAGE PROTECTION

Fuses are installed at the input and outputs of the controller to protect its circuitry in the case of an overload or overvoltage.

COMPUTER CONTROL

The controller can be connected to a computer, thus making it possible to centralize the management of information and diversify control strategies.

LOCATION OF THE CONTROLS

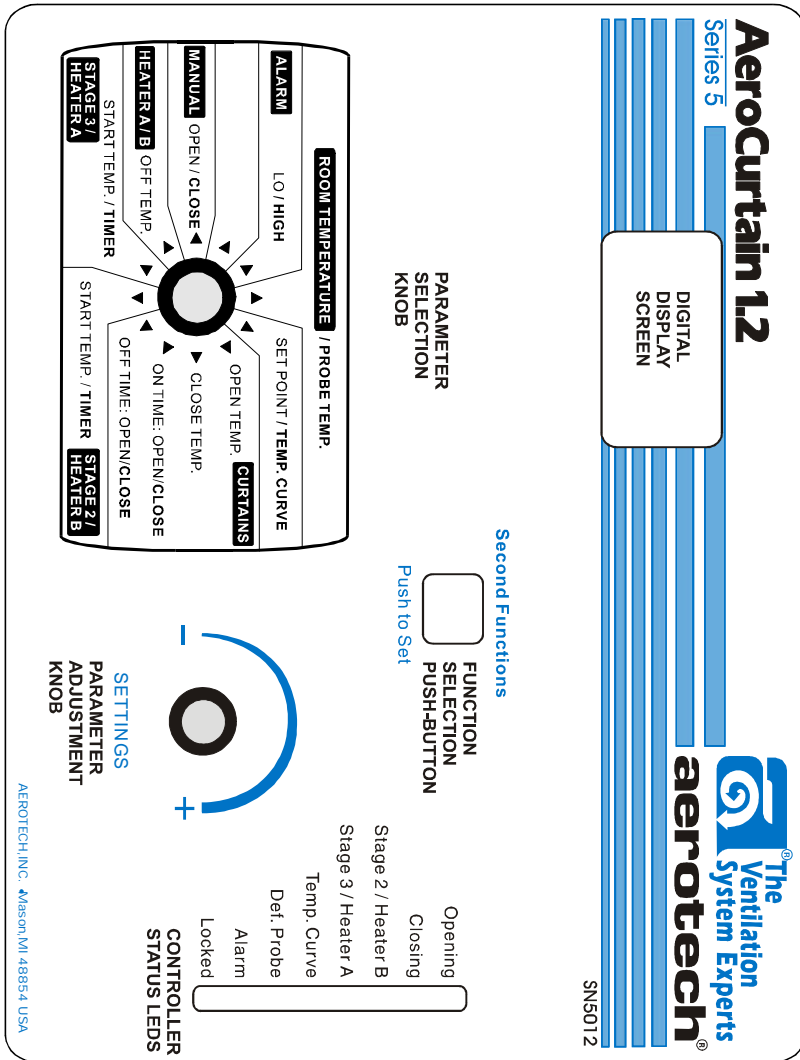

SN 5012

CONTROLLER STATUS LEDS

LED	MEANING
OPENING	TURNS ON WHEN CURTAINS ARE OPENING.
CLOSING	TURNS ON WHEN CURTAINS ARE CLOSING.
STAGE 2 HEATER B	TURNS ON WHEN STAGE 2 FANS, MIST UNITS OR HEATER B UNITS ARE ON.
STAGE 3 HEATER A	TURNS ON WHEN STAGE 3 FANS, MIST UNITS OR HEATER A UNITS ARE ON.
TEMP. CURVE	TURNS ON WHEN THE TEMPERATURE CURVE IS ACTIVATED.
DEF. PROBE	TURNS ON WHEN A DEFECTIVE PROBE IS DETECTED.
ALARM	TURNS ON WHEN AN ALARM IS DETECTED.
LOCKED	TURNS ON WHEN PARAMETERS ARE LOCKED.

INTERNAL SWITCHES



The internal switches are located on the inside of the front cover. When the controller is shipped from the factory, all the switches are set to OFF.

#	OFF	ON
1	UNLOCKED PARAMETERS	LOCKED PARAMETERS
2	FAHRENHEIT DEGREES	CELSIUS DEGREES
3	NO HEATERS	HEATERS
4	1 HEATER	2 HEATERS
5	STAGED HEATERS	ZONED HEATERS
6	STAGE 2 COOLING	STAGE 2 MIST
7	STAGE 3 COOLING	STAGE 3 MIST
8	CURTAIN COMPENSATION OFF	CURTAIN COMPENSATION ON
9	MIST TIMER IN MINUTES	MIST TIMER IN SECONDS
10	RESERVED	
11	RESERVED	
12	RESERVED	

INSTALLATION

MOUNTING INSTRUCTIONS

Open the latch and lift the cover. Remove the black caps located on each of the four mounting holes. Mount the enclosure on the wall using four screws. Be sure the electrical knockouts are at the bottom of the enclosure in order to prevent water from entering the controller. Insert the screws in the mounting holes and tighten. Fasten the four black caps provided with the controller onto the four mounting holes. The enclosure must be mounted in a location that will allow the cover to be completely opened right up against the wall.

CONNECTIONS

To connect the controller, refer to the wiring diagram enclosed with this user's manual.

- Set the voltage switch to the appropriate voltage.
- Use the electrical knockouts provided at the bottom of the enclosure. Do not make additional holes in the enclosure, particularly on the top of the enclosure when using a SL 1400 communication board.
- For the heating stages, it may be necessary to install a transformer in order to supply the appropriate voltage to the heating unit.

ALARM CONNECTION: There are two types of alarms on the market. One type activates when current is cut off at its input, whereas the other activates when current is supplied at its input. For an alarm of the first type, use the NO terminal as shown on the wiring diagram. For an alarm of the second type, use the NC terminal.



ALL WIRING MUST BE DONE BY AN AUTHORIZED ELECTRICIAN AND MUST COMPLY WITH APPLICABLE CODES, LAWS AND REGULATIONS. BE SURE POWER IS OFF BEFORE DOING ANY WIRING TO AVOID ELECTRICAL SHOCKS AND EQUIPMENT DAMAGE.

SN 5012

TEMPERATURE PROBES

1 Connecting the Probes

The controller is supplied with one room probe connected to input # 1. Three additional probes can be connected to inputs # 2, 3 and 4 (see wiring diagram enclosed). If zoned heating is used, Heater A uses probes 1 & 2 and Heater B uses probes 3 & 4. If staged heating is used, the average temperature from activated probes # 1, 2, 3 and 4 is used.

CAUTION: Probes operate at low voltage and are isolated from the supply. Be sure that probe cables remain insulated from all high voltage sources. In particular, do not route the probe cables through the same electrical knockout as other cables. Do not connect the shield from the probe cable to an input or a ground.

2 Extending the Probes

Each probe can be extended up to 500 feet (150 meters). To extend a probe:

- Use a shielded cable of outside diameter between 0.245 and 0.260 in (6.22 and 6.60 mm) (the cable dimensions should not be under 18 AWG) to ensure the cable entry is liquid tight. Do not ground the shielding.
- It is preferable to solder the cable joint to ensure a proper contact between the two cables.

CAUTION: Do not run probe cables next to other power cables. When crossing over other cables, cross at 90°.

3 Defective Probes

If a defective probe is detected, the Defective Probe Pilot Light turns on. The room temperature shown on the display is then the average temperature measured by the probes in working condition. The controller will operate according to this temperature.

To identify the defective probe:

- Set the selection knob to **ROOM TEMPERATURE**. The room temperature is displayed.
- Press the push-button. If the probe connected to input # 1 and supplied with the controller is not defective, the letters "PR1" are displayed, alternating with the temperature measured by the probe. If the probe is defective, the letters "PR1" are displayed, alternating with the letter "P".

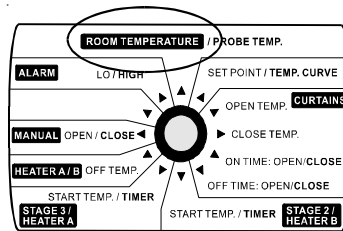

For each additional probe connected to the controller:

- Press the push-button once again. If the probe is not defective, the letters "PR#" (where # is the number of the input to which the probe is connected) are displayed, alternating with the temperature measured by the probe. If the probe is defective, the letters "PR#" are displayed, alternating with the letter "P".

STAGE 2 & 3: COOLING

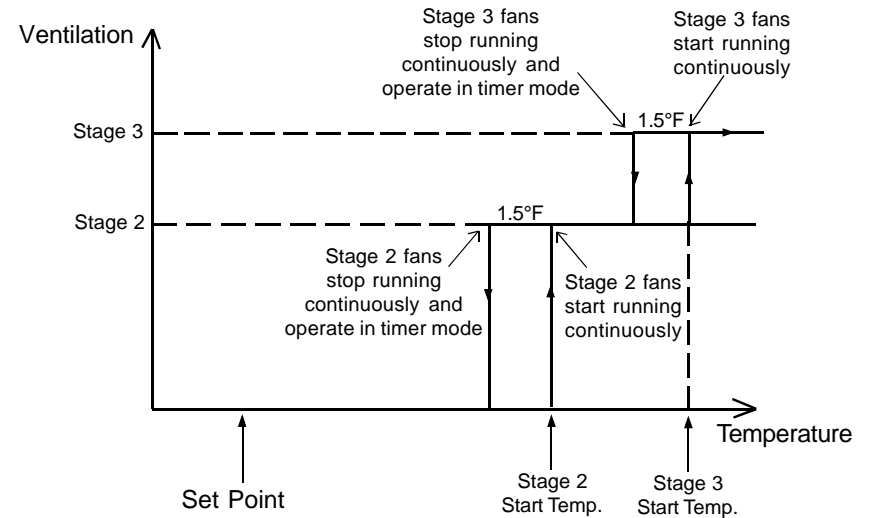
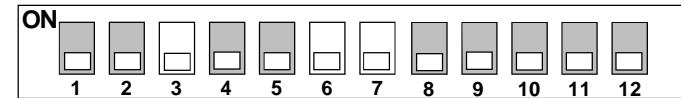

Temperature rises: When the temperature rises to Curtain Opening Temperature, the curtains begin to open intermittently according to the curtain timer settings. At Stage 2 Start Temperature, Stage 2 fans start running continuously. At Stage 3 Start Temperature, Stage 3 fans start running continuously.

Temperature falls: When the temperature falls to Stage 3 Start Temperature - 1.5°F, Stage 3 Fans stop running continuously and operate according to timer 3 settings. At Stage 2 Start Temperature - 1.5°F, Stage 2 fans stop running continuously and operate according to timer 2 settings. At Curtain Closing Temperature, the curtains begin to close intermittently according to the curtain timer settings.

* The controller does not recognize dipswitch combinations other than those given in this section. No other configurations are possible.

STAGE 2 & 3: MIST

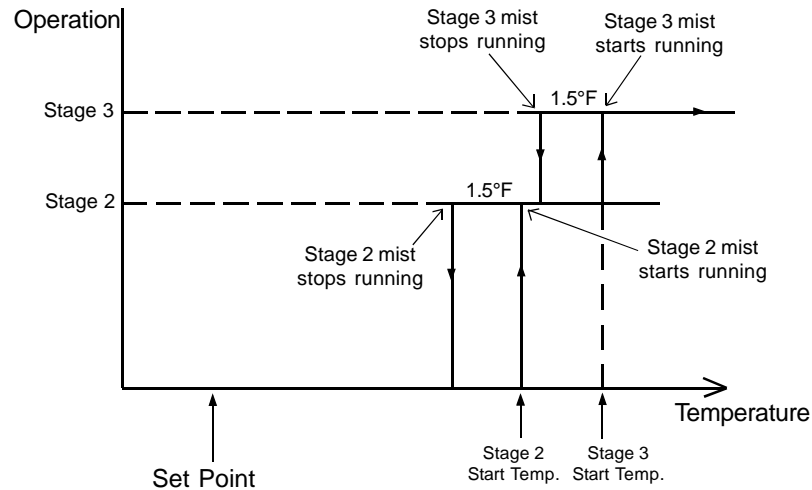
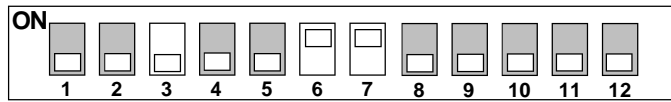

Temperature rises: When the temperature rises to Curtain Opening Temperature, the curtains begin to open intermittently according to the curtain timer settings. At Stage 2 Starting Temperature, the Stage 2 fans start running continuously. At Stage 3 Starting Temperature, the Stage 3 mist units start to run according to the timer 3 settings.

Temperature falls: When the temperature falls to Stage 3 Start Temperature - 1.5°F, the Stage 3 mist units stop running. At Stage 2 Start Temperature - 1.5°F, the Stage 2 fans stop running continuously and operate according to timer 2 settings. At Curtain Closing Temperature, the curtains begin to close intermittently according to the curtain timer settings.

NOTE: The mist timer operates in minutes or seconds depending on the position of internal switch # 9: OFF - 1 to 60 minutes (steps of 1 min.); ON - 0 to 900 seconds (steps of 15 sec.).

STAGE 2: COOLING; STAGE 3: MIST

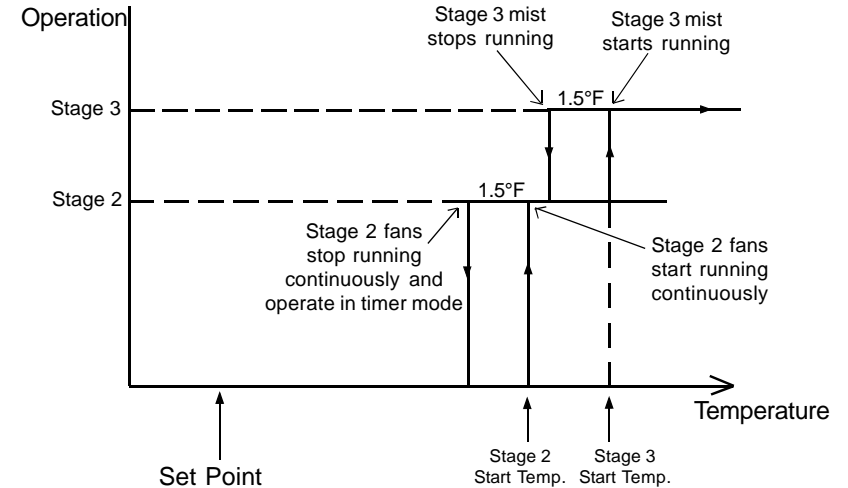
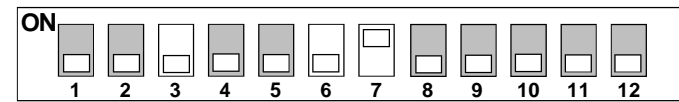

Temperature rises: When the temperature rises to Curtain Opening Temperature, the curtains begin to open intermittently according to the curtain timer settings. At Stage 2 Starting Temperature, the Stage 2 fans start running continuously. At Stage 3 Starting Temperature, the Stage 3 mist units start to run according to the timer 3 settings.

Temperature falls: When the temperature falls to Stage 3 Start Temperature - 1.5°F, the Stage 3 mist units stop running. At Stage 2 Start Temperature - 1.5°F, the Stage 2 fans stop running continuously and operate according to timer 2 settings. At Curtain Closing Temperature, the curtains begin to close intermittently according to the curtain timer settings.

NOTE: The mist timer operates in minutes or seconds depending on the position of internal switch # 9: OFF - 1 to 60 minutes (steps of 1 min.); ON - 0 to 900 seconds (steps of 15 sec.).

STAGE 2: MIST; STAGE 3: HEATING

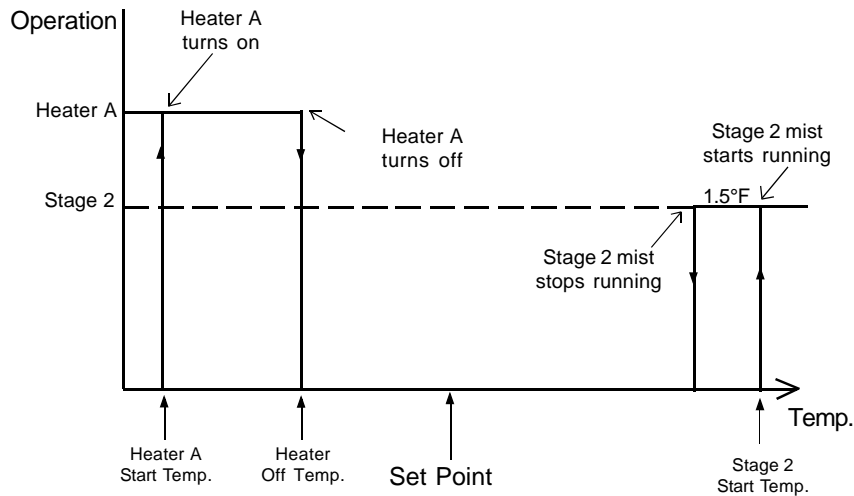
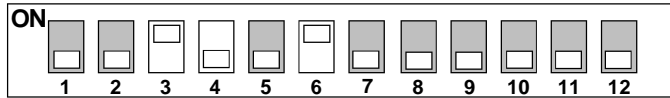

Temperature rises: When the temperature rises to Heater Off Temperature, Heater A turns off. At Curtain Opening Temperature, the curtains begin to open intermittently according to the curtain timer settings. At Stage 2 Starting Temperature, the Stage 2 mist units start to run according to the timer 2 settings.

Temperature falls: When the temperature falls to Stage 2 Start Temperature - 1.5°F, the Stage 2 mist units stop running. At Curtain Closing Temperature, the curtains begin to close intermittently according to the curtain timer settings. At Heater A Starting Temperature, Heater A turns on.

NOTE: The mist timer operates in minutes or seconds depending on the position of internal switch # 9: OFF - 1 to 60 minutes (steps of 1 min.); ON - 0 to 900 seconds (steps of 15 sec.).

STAGE 2: COOLING; STAGE 3: HEATING

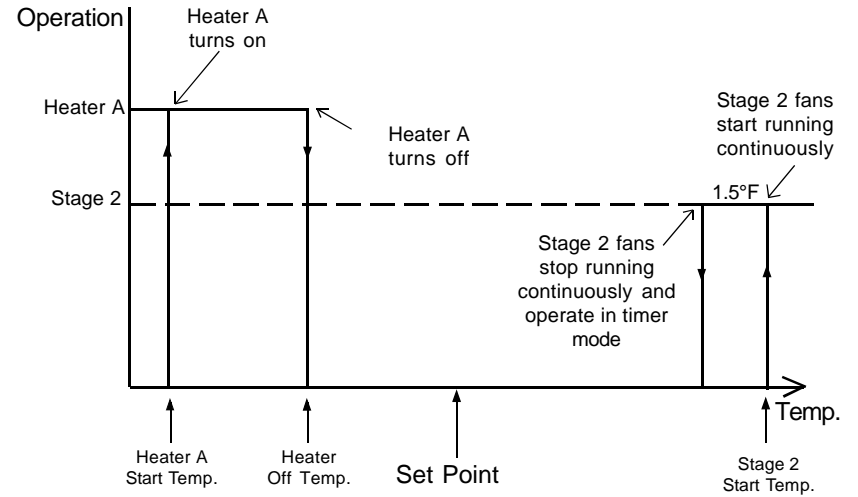
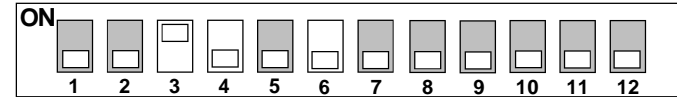

Temperature rises: When the temperature rises to Heater Off Temperature, Heater A turns off. At Curtain Opening Temperature, the curtains begin to open intermittently according to the curtain timer settings. At Stage 2 Starting Temperature, the Stage 2 fans start running continuously.

Temperature falls: When the temperature falls to Stage 2 Start Temperature - 1.5°F, the Stage 2 fans stop running continuously and operate according to timer 2 settings. At Curtain Closing Temperature, the curtains begin to close intermittently according to the curtain timer settings. At Heater A Starting Temperature, Heater A turns on.

STAGE 2 & 3: ZONED HEATERS

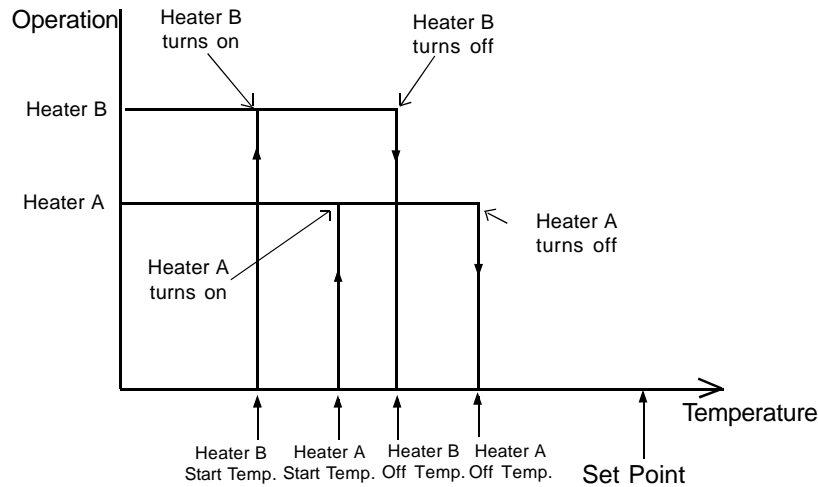
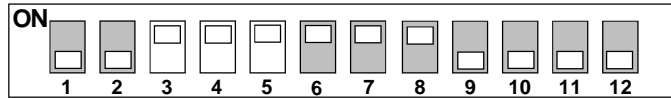

Temperature rises: When the average temperature from probes 3 and 4 rises to Heater B Off Temperature, Heater B turns off. When the average temperature from probes 1 and 2 rises to Heater A Off Temperature, Heater A turns off. When the average temperature from all probes reaches Curtain Opening Temperature, the curtains begin to open intermittently according to the curtain timer settings.

Temperature falls: When the average temperature from all probes falls to Curtain Closing Temperature, the curtains begin to close intermittently according to the curtain timer settings. At Heater A Starting Temperature on probes 1 and 2, Heater A turns on. At Heater B Starting Temperature on probes 3 and 4, Heater B turns on.

NOTE: If all the probes in a zone are defective, the corresponding heater operates according to the average temperature of remaining probes.

STAGE 2 & 3: STAGED HEATERS

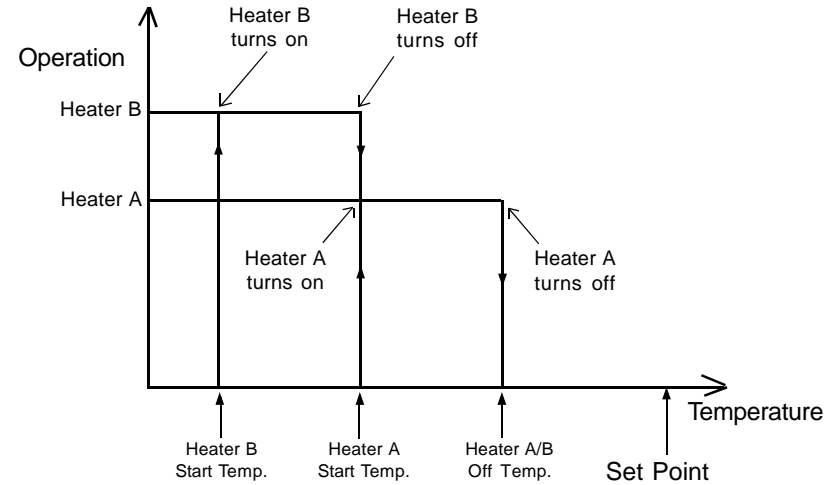
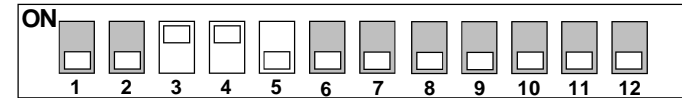

Temperature rises: When the temperature rises to Heater A Starting Temperature, Heater B turns off. At Heater A/B Off Temperature, Heater A turns off. At Curtain Opening Temperature, the curtains begin to open intermittently according to the curtain timer settings.

Temperature falls: When the temperature falls to Curtain Closing Temperature, the curtains begin to close intermittently according to the curtain timer settings. At Heater A Starting Temperature, Heater A turns on. At Heater B Starting Temperature, Heater B units turn on.

NOTE: The heaters operate according to the average temperature read by the controller.

CHANGING THE PARAMETER SETTINGS

THE MEANING OF A FLASHING DISPLAY

The display will flash in certain cases and not in others. The flashing indicates that the value shown can be adjusted. A value that is not flashing cannot be adjusted.

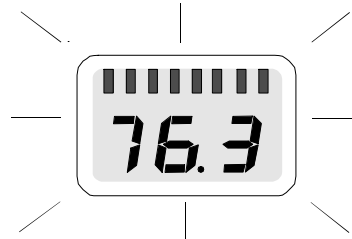

LOCKING THE PARAMETER SETTINGS

The parameter settings can be locked to prevent accidentally modifying them. When the settings are locked, only the temperature set point can be modified (as long as the temperature curve is deactivated).

To lock the parameter settings:

- Set internal switch # 1 to **ON**. The Locked Parameter Pilot Light turns on.

To unlock the parameter settings:

- Set internal switch # 1 to **OFF**. The Locked Parameter Pilot Light turns off.

TEMPERATURE SETTINGS

TEMPERATURE UNITS

Temperatures can be displayed in either Celsius or Fahrenheit units

- Set internal switch # 2 to the desired position:

- **ON** to display temperatures in Celsius units.
- **OFF** to display temperatures in Fahrenheit units.

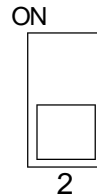

VIEWING TEMPERATURES

The readout can display values from -40.0°F to 120°F (-40.0°C to 48.9°C). When the temperature drops below -9.9 degrees, the negative sign is displayed separately, alternating with the numerical value.

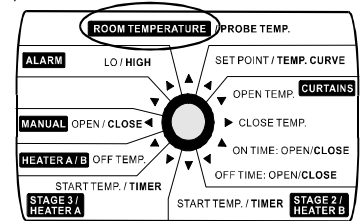

1 Viewing the Room Temperature

The room temperature is the average value of all temperatures measured by activated probes in proper operating condition.

- Set the selection knob to **ROOM TEMPERATURE / PROBE TEMP.** The room temperature is displayed.

2 Viewing the Probe Temperatures

The controller can display probe temperatures individually. Probes can also be turned on or off to control the temperature in different parts of the building.

- Set selection knob to **ROOM TEMPERATURE / PROBE TEMP.** The average room temperature is displayed.

SN 5012

- Press the push-button. The temperature reading from probe 1 is displayed, alternating with the letters "Pr 1".
- For each additional probe, press the push-button. The temperature reading from probe x is displayed, alternating with the letters "Pr x", etc.
- Press the push-button once again to display the state of probe 1, i.e. ON / OFF. When a probe is activated, it is used in the calculation of the average room temperature.
- Use the adjustment knob to change the state of the probe.
- For each additional probe, press the push-button. The state of probe is displayed, alternating with the letters "Pr x", etc.

Notes:

- At least one probe must be activated at all times. If only one probe remains active, the controller will lock the on/off switch for that probe.
- The display returns to the average room temperature after one minute.
- Initially, only probe one is activated.

3 Viewing Minimum / Maximum Temperatures

The minimum and maximum temperatures are the lowest and highest temperature values recorded since the last reset. Temperatures values are averaged over all active probes.

- Set the selection knob to **ROOM TEMPERATURE / PROBE TEMP**. The room temperature is displayed.
- Turn the adjustment knob clockwise by one notch. The minimum temperature flashes on the display, alternating with the letters "Lo".

SN 5012

- Turn the adjustment knob clockwise one notch further. The maximum temperature flashes on the display, alternating with the letters "Hi".
- Turn the adjustment knob clockwise a third notch. The room or outside temperature is displayed again.
- For each individual probe, press the push-button. The temperature reading from probe x is displayed, alternating with the letters "Pr x".
- Turn the adjustment knob clockwise by one notch. The minimum is displayed, alternating with the letters "Lo".
- Turn the adjustment knob clockwise one notch further. The maximum temperature is displayed, alternating with the letters "Hi".
- Turn the adjustment knob clockwise a third notch. The probe temperature is displayed again.

NOTE: If you let the display flash for more than 10 seconds, the controller resets the minimum and maximum temperatures currently in memory (the display stops flashing to indicate that the reset has been done).

TEMPERATURE SET POINT

The temperature set point is the target room temperature. It can be adjusted between -40.0°F and 99.9°F (-40.0°C and 37.7°C).

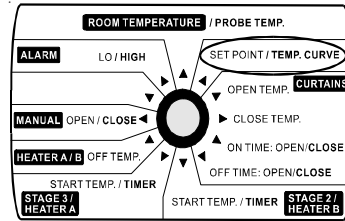

Adjusting the Temperature Set Point

- Set the selection knob to **SET POINT / TEMP. CURVE**. The current set point flashes on the display.
- Use the adjustment knob to adjust the set point to the desired value.

NOTE: The temperature set point can be adjusted only if the temperature curve is deactivated (see following section).

TEMPERATURE CURVE

The user can define a temperature curve to adjust the set point automatically over a given time period.

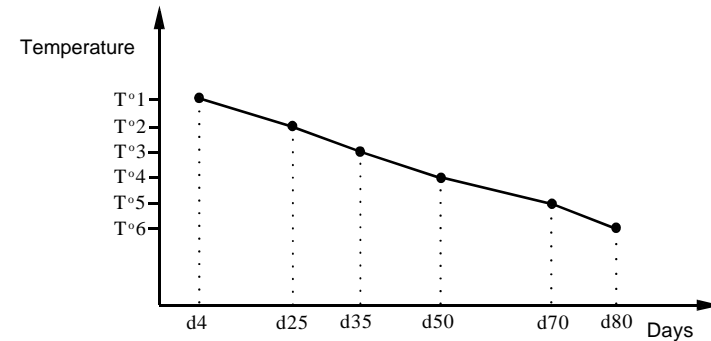

A curve is defined using six points. Each point specifies a day number and a set point for that day. Once the points of the curve are defined, the curve must be activated. The controller will change the temperature set point every hour in a linear fashion between consecutive points of the curve. When the last point of the curve is reached, the temperature set point for that day is maintained until the curve is reactivated.

NOTES :

- i) All six points of the curve must be specified. If six points are not needed, repeat the last temperature value for each unnecessary point.
- ii) Certain restrictions apply to reduce the risk of errors:
 - The highest possible day number is 99.
 - Decreasing day numbers are not allowed.
 - Increasing temperatures are not allowed.
 - The temperature variation cannot exceed 3°F (1.6°C) per day.

1 Specifying the Curve

- Set the selection knob to **SET POINT / TEMP. CURVE**. The current temperature set point flashes on the display.
- Press the push-button. The word **OFF** is displayed indicating that the temperature curve is deactivated. If this is not the case, see below to deactivate the curve.

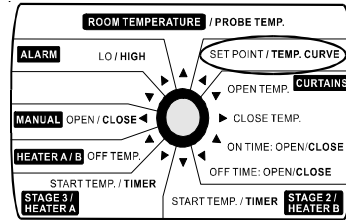

Repeat the following steps for each of the six points:

- Press the push-button once again. The word "**day**" is displayed, alternating with a day number.
- Using the adjustment knob, set the day number to the desired value.
- Press the push-button once again. The current temperature set point is displayed, alternating with the word "**set**".
- Using the adjustment knob, adjust the set point to the desired value.

Once the six points of the curve have been specified, activate the curve as explained below.

NOTE: Make sure the temperature curve is deactivated before specifying new points (see below).

2 Activating the Temperature Curve

If you have just finished specifying the points on the curve:

- Press the push-button once again. The word **OFF** flashes on the display.
- Turn the adjustment knob clockwise one notch. The word **ON** flashes on the display, the Temperature Curve Pilot Light flashes, indicating that the temperature curve is now activated.
- Set the selection knob to **ROOM TEMPERATURE**.

If you have previously defined the points on the curve:

- Set the selection knob to **SET POINT / TEMP. CURVE**. The current value of the temperature set point flashes on the display.
- Press the push-button. The word **OFF** is displayed.
- Press the push-button to display the points of the curve currently defined until the word **OFF** appears (thirteen clicks).
- Turn the adjustment knob clockwise one notch. The word **ON** flashes on the display and the Temperature Curve Pilot Light flashes, indicating that the temperature curve is now activated.
- Set the selection knob to **ROOM TEMPERATURE**.

3 Viewing Current Set Point and Day Number

When the temperature curve is activated, the current temperature set point and day number can be viewed at any time. The current day number can also be adjusted in order to move forward or backward on the temperature curve.

- Set the selection knob to **SET POINT / TEMP. CURVE**. The current temperature set point is displayed.
- Press the push-button. The current day number flashes on the display.
- Use the adjustment knob to set the day number to the desired value.

4 Deactivating the Temperature Curve

- Set the selection knob to **SET POINT / TEMP. CURVE**. The current temperature set point is displayed.
- Press the push-button to display the points of the curve actually defined until the word **ON** appears (fourteen clicks).
- Turn the adjustment knob counterclockwise one notch. The word **OFF** flashes on the display and the Temperature Curve Pilot Light turns off indicating that the temperature curve is now deactivated.
- Set the selection knob to **ROOM TEMPERATURE**.

PRINCIPLE OF OPERATION

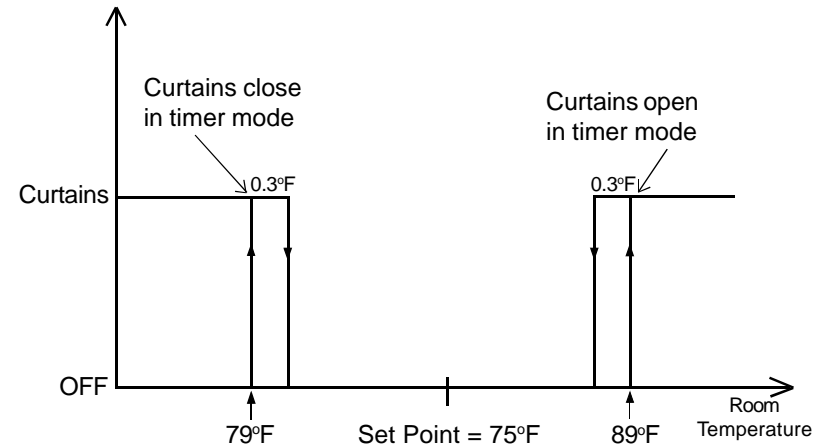

In the example above, when the temperature rises to 89°F, the curtains begin to open and continue to do so until fully open if the temperature remains above this point. If the temperature falls to 88.7°F, the curtains stop opening.

The curtains open intermittently according to the open curtain on time and off time settings:

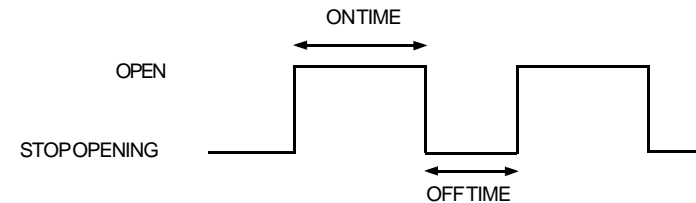

The curtains close intermittently according to the close curtain on time and off time settings.

SETTINGS

1 Adjusting the Opening and Closing Temperatures

The opening and closing temperatures are the temperature values at which the curtains open or close. The hysteresis is fixed at 0.3°F and determines when the curtains stop operating. The opening and closing temperatures can be adjusted from 0.5°F to 20.0°F (0.3°C to 11.1°C) above and below the set point respectively.

- Set the selection knob to **CURTAINS – OPEN TEMP.** The current curtain opening temperature flashes on the display, alternating with the letters **OPE**.
- Use the adjustment knob to set the opening temperature to the desired value.
- Set the selection knob to **CURTAINS – CLOSE TEMP.** The current curtain closing temperature flashes on the display, alternating with the letters **CLO**.
- Use the adjustment knob to set the closing temperature to the desired value.

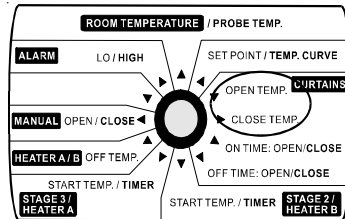

2 Adjusting the Open Curtain Timer

The on and off time parameters can take values from 0 to 900 seconds.

- Set the selection knob to **CURTAINS - ON TIME.** The current open curtain on time flashes on the display, alternating with the word **On** and **OPE**.
- Use the adjustment knob to set the on time to the desired value.
- Set the selection knob to **CURTAINS - OFF TIME.** The current open curtain off time flashes, alternating with the word **Off** and **OPE**.
- Use the adjustment knob to set the off time to the desired value.

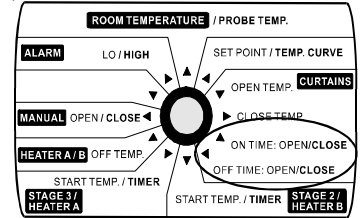

3 Adjusting the Close Curtain Timer

The on and off time parameters can take values from 0 to 900 seconds.

- Set the selection knob to **CURTAINS - ON TIME.** The current open curtain on time flashes on the display, alternating with the word **On** and **OPE**.
- Press the push-button. The current close curtain on time flashes on the display, alternating with the word **On** and **CLO**.
- Use the adjustment knob to set the on time to the desired value.
- Set the selection knob to **CURTAINS - OFF TIME.** The current open curtain off time flashes, alternating with the word **Off** and **OPE**.
- Press the push-button. The current close curtain off time flashes on the display, alternating with the word **Off** and **CLO**.
- Use the adjustment knob to set the off time to the desired value.

CURTAIN OPERATING TIME COMPENSATION

When curtain compensation is turned on, the controller uses the current room temperature to gradually adjust the timer settings for opening and closing the curtains as the temperature departs from the set point. The higher the room temperature, the faster the curtains open. Likewise, the lower the room temperature, the faster the curtains close. To use this feature, set internal switch # 8 to ON.

Temperature Rises:

When the room temperature rises above the curtain opening temperature, the controller increases the on time and decreases the off time settings for the opening cycle such that the total cycle time remains constant.

When the off time is below 10 seconds, the curtains begin to open continuously.

EXAMPLE 1

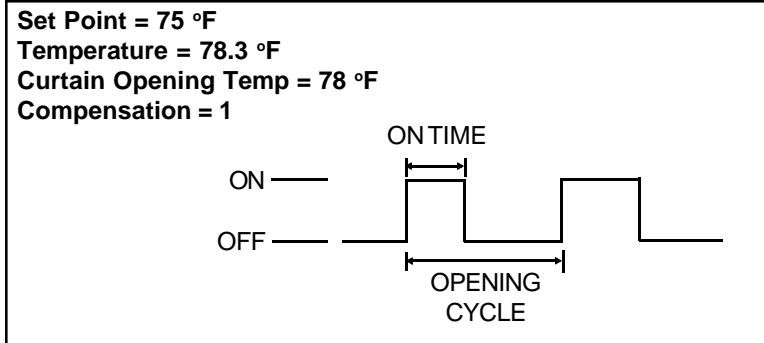

The difference between the current temperature and the opening temperature of the curtains is 0.3 degrees Fahrenheit. According to Table 1 below, this gives a compensation factor of one. Therefore, the on time for opening the curtains maintains its current value.

$$\begin{array}{rcl}
 \text{Current Temp.:} & & 78.3 \text{ °F} \\
 \text{Opening Temp.:} & - & 78.0 \text{ °F} \\
 \hline
 & = & \mathbf{0.3 \text{ °F}}
 \end{array}$$

Table 1. Compensation Factors

Temperature rises above Opening Temp	Temperature falls below Closing Temp	Compensation Factor
Current Temp. - Opening Temp.	Closing Temp. - Current Temp.	
0.0 to 1.9°F (0 to 1.1°C)	0.0 to 1.9°F (0 to 1.1°C)	1
2.0 to 2.9°F (1.1 to 1.6°C)	2.0 to 2.9°F (1.1 to 1.6°C)	2
3.0 to 3.9°F (1.7 to 2.2°C)	3.0 to 3.9°F (1.7 to 2.2°C)	3
etc...	etc...	etc...

EXAMPLE 2

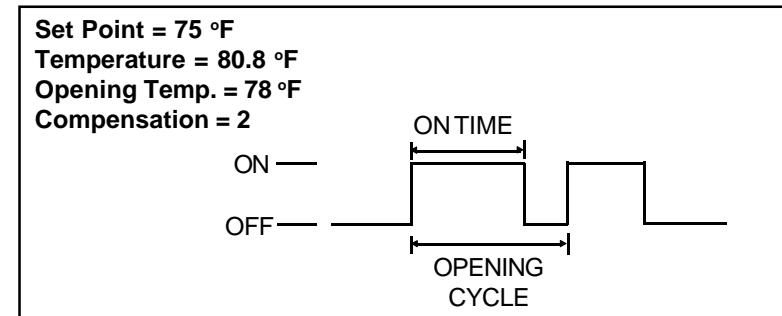

In Example 2, the difference between the current temperature and the opening temperature has risen to 2.8°F. According to Table 1 above, this gives a compensation factor of two. Therefore, the on time value is doubled.

Temperature Falls:

When the room temperature falls below the curtain closing temperature, the controller increases the on time and decreases the off time settings for the closing cycle such that the total cycle time remains constant.

When the off time is below 10 seconds, the curtains begin to close continuously. The controller uses the compensation factors given in Table 1.

VENTILATION AND MIST SETTINGS

Stages 2 and 3 can be used to operate constant-speed fans or mist units. The chart below sums up the possible internal switch settings :

CONFIGURATION	SWITCH SETTINGS
STAGE 2 FANS	3 - OFF; 6 - OFF
	3 - ON; 4 - OFF; 6 - OFF
STAGE 2 MIST	3 - OFF; 6 - ON
	3 - ON; 4 - OFF; 6 - ON
STAGE 3 FANS	3 - OFF; 7 - OFF
STAGE 3 MIST	3 - OFF; 7 - ON

1 Adjusting the Stage 2 or 3 Starting Temperature

The starting temperature is the temperature at which the fans start running continuously or the temperature at which the mist units start running in timer mode (see the Configurations section). The hysteresis is fixed at 1.5°F. It determines when the fans stop running continuously and start operating in timer mode or when the mist units stop running.

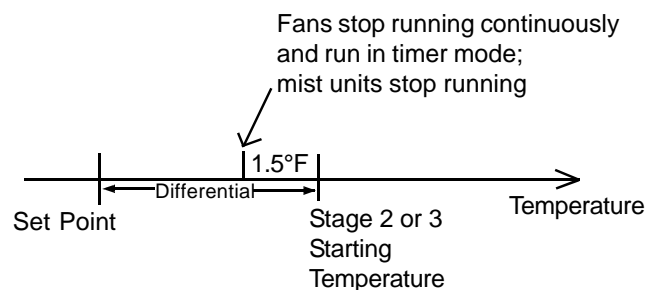

The differential shown above can go from 0.5°F to 20.0°F (0.3°C to 11.1°C). If this value is less than 1.5°F, the hysteresis is adjusted to the new differential.

SN 5012

- Set the selection knob to **STAGE 2 — START TEMP./TIMER** or **STAGE 3 — START TEMP./TIMER**. The current starting temperature flashes on the display.

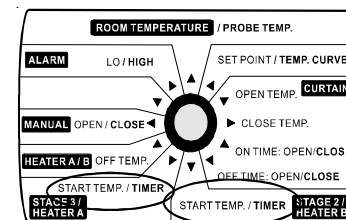

- Use the adjustment knob to adjust the temperature to the desired value.

2 Adjusting the Timer Settings

The timer is used to operate the mist units when the starting temperature of the stage has been reached. In the case of cooling fans, the timer is used to provide minimum ventilation when the temperature drops 1.5°F below the starting temperature. The timer operates as shown below:

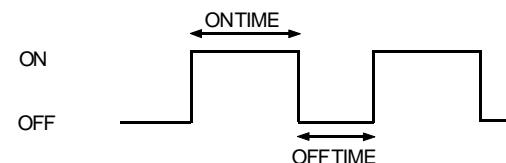

- Set the selection knob to **STAGE 2 — START TEMP./TIMER** or **STAGE 3 — START TEMP./TIMER**. The current starting temperature flashes on the display.
- Press the push-button. The on time is displayed, alternating with the word "On".
- Use the adjustment knob to set the on time to the desired value.
- Press the push-button. The off time is displayed, alternating with the word "OFF".
- Use the adjustment knob to set the off time to the desired value.

HEATER SETTINGS

STAGED HEATERS

To configure your system for staged heaters, set dipswitch #3 and #4 to ON and # 5 to OFF. All heaters operate according to the average reading from all temperature probes and only one heater off temperature is needed.

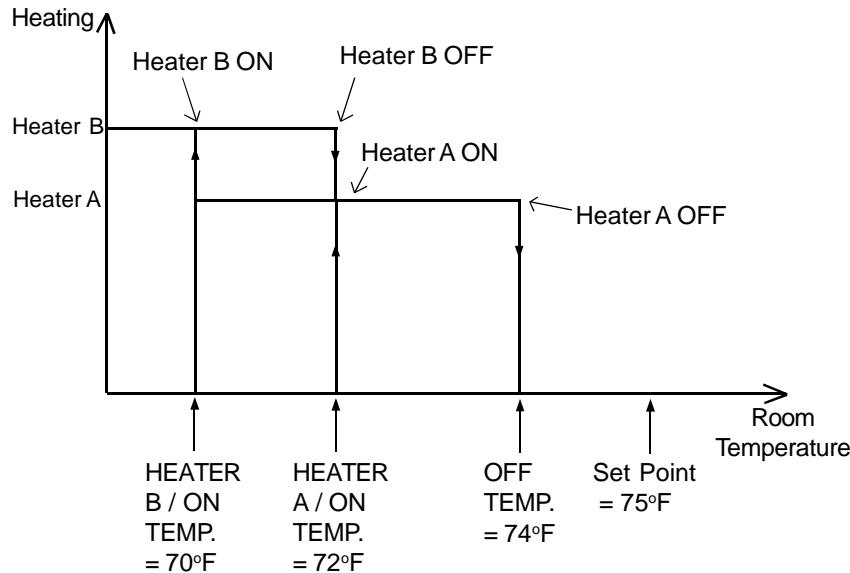

If the room temperature rises:

- at 72°F: Heater B turns off.
- at 74°F: Heater A turns off.

If the room temperature falls:

- at 72°F: Heater A turns on.
- at 70°F: Heater B turns on.

1 Adjusting Starting Temperatures for Staged Heaters

The heater starting temperature is the temperature at which the heating units turn on (see diagram above). The Heater A starting temperature is bounded above by the off temperature — 0.5°F and below by the off temperature — 20°F. The Heater B starting temperature is bounded above by the Heater A starting temperature — 0.5°F and below by the Heater A starting temperature — 20°F.

- Set selection knob to **HEATER A — START TEMP.** The current starting temperature for Heater A is displayed, alternating with the letters "Ht.A".
- Use the adjustment knob to adjust the starting temperature to the desired value.
- Set selection knob to **HEATER B — START TEMP.** The current starting temperature for Heater B is displayed, alternating with the letters "Ht.b".
- Use the adjustment knob to adjust the starting temperature to the desired value.

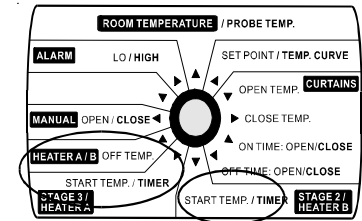

2 Adjusting Off Temperatures for Staged Heaters

The heater off temperature can provide substantial energy savings if correctly adjusted according to the outside temperature. It is the temperature below the set point at which the heating units turn off (see diagram above). The off temperature is bounded above by the set point + 10°F and below by the set point — 20°F.

- Set selection knob to **HEATER A/B — OFF TEMP.** The current off temperature is displayed, alternating with the letters "Ht.A".

- Use the adjustment knob to adjust the off temperature to the desired value.

ZONED HEATERS

To configure your system for zoned heaters, set dipswitch #3, #4 and #5 to ON. Since the two heater outputs function independently, different probes are assigned to each output: Probes 1 & 2 are assigned to Heater A and Probes 3 & 4 are assigned to Heater B. Individual probes can be turned on or off using the push-button functions contained in the ROOM TEMPERATURE function (see section on Temperature Settings).

Note that the heaters can become active only if the average temperature from all activated probes is below the set point. If this isn't the case, the heaters will not turn on even if individual probe temperatures are below the set point (this condition applies only if both off temperatures are below the set point).

The figure below explains the operation of zoned heaters.

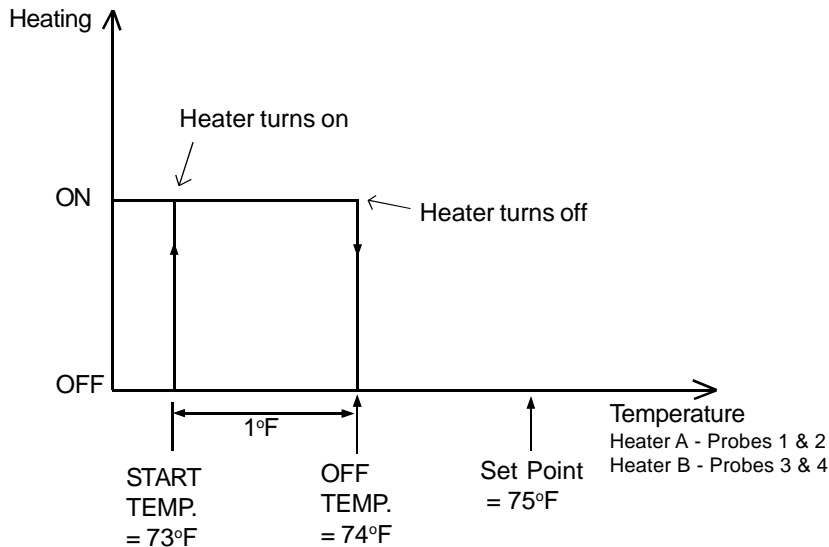

If the room temperature rises:

- at 74°F: Heater A (Probes 1 & 2) turns off.
Heater B (Probes 3 & 4) turns off.

If the room temperature falls:

- at 73°F: Heater A (Probes 1 & 2) turns on.
Heater B (Probes 3 & 4) turns on.

1 Adjusting Off Temperatures for Zoned Heaters

The heater off temperature can provide substantial energy savings if correctly adjusted according to the outside temperature. It is the temperature below the set point at which the heating units turn off (see diagram above). The off temperature is bounded above by the set point + 10°F (5.6°C) and below by the set point — 20°F (11.1°C).

- Set selection knob to **HEATER A/B — OFF TEMP.** The current off temperature for Heater A is displayed, alternating with the letters "Ht.A".
- Use the adjustment knob to adjust the off temperature to the desired value.
- Press the push-button. The current off temperature for Heater B is displayed, alternating with the letters "Ht.b".
- Use the adjustment knob to adjust the off temperature to the desired value.

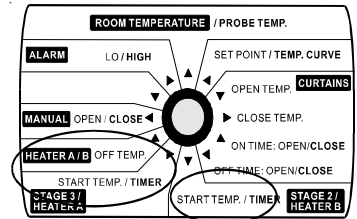

2 Adjusting Starting Temperatures for Zoned Heaters

The starting temperature is the temperature at which the heater turns on. The Heater A starting temperature is bounded above by the off temperature — 0.5°F and below by the off temperature — 20°F. The Heater B starting temperature is bounded above by the Heater B off temperature — 0.5°F and below by the Heater B off temperature — 20°F.

- Set the selection knob to **HEATER A — START TEMP.** The current starting temperature for Heater A is displayed, alternating with the letters "**Ht.A**".
- Use the adjustment knob to adjust the starting temperature to the desired value.
- Set the selection knob to **HEATER B — START TEMP.** The current starting temperature for Heater B is displayed, alternating with the letters "**Ht.B**".
- Use the adjustment knob to adjust the starting temperature to the desired value.

ALARM SETTINGS

The controller sets off an alarm in the case of a power failure, a fault in the supply circuit or a high or low temperature. Temperature alarms are defined according to the set point as shown in the diagram below.

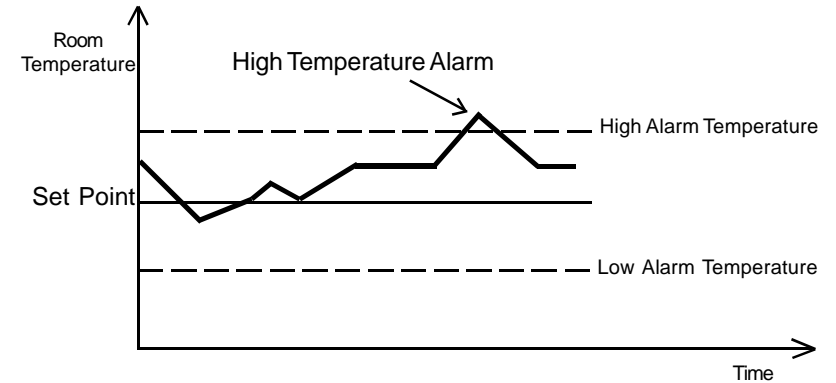

Adjusting the Alarm Settings

The high and low alarm settings are specified as a temperature value. The high alarm temperature ranges from set point + 0.5°F to set point + 40°F. The low alarm temperature ranges from set point - 40°F to set point - 0.5°F.

- Set the selection knob to **ALARM — LO / HIGH.** The current low alarm temperature flashes on the display, alternating with the word "**LO**".
- Use the adjustment knob to set the low alarm temperature to the desired value.
- Press the push-button. The current high alarm temperature flashes on the display, alternating with the word "**HI**".
- Use the adjustment knob to set the high alarm temperature to the desired value.

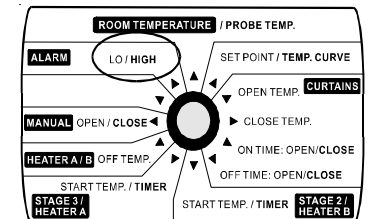

TROUBLESHOOTING GUIDE

PROBLEM	CAUSE	SOLUTION
There is no display.	The circuit breaker at the service panel is off or tripped.	Correct the problem and reset the circuit breaker.
	The wiring is incorrect.	Correct the wiring.
	The voltage selector switch is in the wrong position.	Set the switch to the correct position.
	The display board interconnect cable is not properly plugged into the power supply board.	Be sure the cable is firmly plugged in.
The display shows "P" when the parameter selection knob is set to ROOM TEMPERATURE.	A room probe is connected improperly.	Correct the room probe connection.
	A room probe is defective.	Refer to "defective probes"
The defective probe pilot light is on.	A probe is defective.	Refer to "defective probes"

SN 5012

PROBLEM	CAUSE	SOLUTION
The display shows sudden variations in the room or outside temperature.	A variation in resistance is induced on a probe.	Be sure the probes are dry. Locate them away from drafts and sources of radiant heating. Be sure the outside probe is installed correctly. Refer to "Installing the outside probe"
	There is electrical noise near a probe cable.	Isolate the probe cables from all high voltage sources. Do not route probe cables and other power cables through the same electrical knockout. Do not run probe cables next to other power cables. When crossing other power cables, cross at 90°.
The curtains do not work.	The fuse on the curtain output is blown.	Replace the fuse.
The mist is not operating as desired.	The mist time on and time off were incorrectly adjusted.	When internal switch #9 is OFF, the mist time on and time off are in <u>minutes</u> . Otherwise, they are in seconds. Adjust the mist time on and time off correctly.

SN 5012

PROBLEM	CAUSE	SOLUTION
<p>The cooling fans are not running.</p> <p>or</p> <p>The heaters are not turning on.</p>	The wiring is incorrect.	Correct the wiring. Be sure two different lines are connected to each fan motor or heater: the controller's output line L1 should be combined with another line (N for 115V or L2 for 230V) to activate the fan motor or heater. Also, be sure the stage's COMMON is supplied by line L1.
	The stage's fuse is open.	Replace the fuse.
	The display board interconnect cable is not properly plugged into the power supply board.	Be sure the cable is firmly plugged in.
	The fan motor or heater is defective.	Check if the motor or heater is defective by connecting it to an alternate power supply. If it still is not operating, replace the motor or heater.
	The controller is defective.	Listen to see if there is a clicking sound when the stage or heater pilot light turns on. If there is no clicking sound, contact your distributor to repair the controller.

TECHNICAL SPECIFICATIONS

Supply: - 115/230 VAC (-18%, +8%), 50/60 Hz, overload and overvoltage protection fuse F10-1A fast blow.

- 12 VDC for AC back-up supply; can activate stages 2 and 3 and alarm if supplied with DC back-up voltage.

Curtains: OPEN-CLOSE output, 115/230 VAC, 50/60Hz, 30VDC, 5A winch output, fuse F1-5A fast blow.

Stage 2: ON-OFF output, 115/230 VAC, 50/60 Hz, 30VDC, 6A FAN, 10A RES, fuse F3-10A slow blow.

Stage 3: ON-OFF output, 115/230 VAC, 50/60 Hz, 30VDC, 6A FAN, 10A RES, fuse F4-10A slow blow.

Alarm: ON-OFF output, 115/230 VAC, 50/60 Hz, 30VDC, 3A, fuse F9-3A slow blow.

Probes: Low voltage (< 5V), isolated from the supply. Operating range: -40.0° to 120.0°F (-40.0° to 48.9°C). Accuracy: 1.8°F (1°C) between 41° and 95°F (5° and 35°C).

Enclosure: ABS, moisture and dust-tight.

The room temperature where the controller is located MUST ALWAYS REMAIN BETWEEN 32° AND 104°F (0° AND 40°C).

FACTORY SETTINGS

PARAMETER		FACTORY SETTING	RANGE OF VALUES
Temperature Set Point		75°F (23.9°C)	-40 to 99.9°F (-40 to 37.7°C)
Curtains	Opening Temp.	78°F (25.6°C)	0.5°F(0.3°C) to 20°F(11.1°C) above Set Point
	Closing Temp.	72°F (22.2°C)	0.5°F(0.3°C) to 20°F (11.1°C) below Set Point
	Open Curtain On Time	15 seconds	0 to 900 seconds in increments of 15 seconds
	Open Curtain Off Time	15 seconds	
	Close Curtain On Time	15 seconds	
Close Curtain Off Time	15 seconds		
Stage 2	Starting Temp.	77°F (25°C)	0.5°F(0.3°C) to 20°F (11.1°C) above Set Point
	Time On	15 seconds	0 to 900 seconds in increments of 15 seconds (or 1 to 60 minutes)
	Time Off	15 seconds	
Stage 3	Starting Temp.	79°F (26.1°C)	0.5°F(0.3°C) to 20°F (11.1°C) above Set Point
	Time On	15 seconds	0 to 900 seconds in increments of 15 seconds (or 1 to 60 minutes)
	Time Off	15 seconds	
Heater A / B Off Temp.		74.5°F (23.6°C)	10°F(5.6°C) above Set Point to 20°F (11.1°C) below Set Point
Alarm	Low Temp.	65°F (18.3°C)	0.5°F(0.3°C) to 40°F (22.2°C) below Set Point
	High Temp.	87°F (30.6°C)	0.5°F(0.3°C) to 40°F (22.2°C) above Set Point

NOTES:

- i) These initial parameter settings will not be retained in the controller's memory. Each new setting will replace the preceding one.
- ii) If the power supply is cut off, the last parameter settings will be retained in memory until the power is restored.